

**LAB MANUAL
FOR
POWER ELECTRONIC & PLC LAB
SEMESTER-5TH
DEPARTMENT OF ELECTRICAL ENGINEERING**



**GOVT. POLYTECHNIC
SONEPUR**

LIST OF EXPERIMENTS

SI No.	Name of the Experiments
I	(a) Power Electronics
1	Study of V-I characteristics of SCR.
2	Study of V-I characteristics of TRIAC.
3	Study of V-I characteristics of DIAC.
4	Study of drive circuit for SCR & TRIAC using DIAC.
5	Study of drive circuit for SCR & TRIAC using UJT.
6	Study of single phase half wave controlled rectifier with resistive load
7	Study of single phase full wave controlled rectifier (Mid-point configuration) with resistive load.
8	To study phase controlled bridge rectifier using resistive load .
9	study series inverter .
10	To study single phase Cyclo -converter
11	To perform the speed control of DC motor using chopper.
12	Study to voltage source inverter .
13	Study of switching characteristics of a power transistor.
II	(b) PLC Programming.
1.	Introduction /familiarization PLC trainer and its installation with PC
	(a) Learn the basics And hardware components of PLC
	(b) Understand configuration of PLC system .
	(c) Study various building blocks of PLC
	(d) Determine the no. of digital I/O & analog I/O
2.	Execute the different ladder diagrams
	(a) Demonstrate PLC and ladder diagram preparations downloading and running.
	(b) Execute ladder diagrams for different logical gates.
	(c) Execute ladder diagrams using timers and counters .
3.	Execute the ladder diagrams with model applications
	(a) DOL starter
	(b) Star – delta starter
4.	Execute ladder diagram with model applications
	(a) Stair case lighting
	(b) Traffic light controller.

EXPERIMENT NO – 1

AIM OF THE EXPERIMENT:-

To study of characteristic of SCR and plotting V-I characteristics.

OBJECTIVES:-

1. Operation of SCR.
2. V-I Characteristics of SCR.

EQUIPMENTS REQUIRED:-

1. D.C Power Supplies +15v,+35v
2. Digital multi-meter
3. 2mm patchcords.

THEORY:-

SCR is one of the most important type of power semiconductor devices. They are operated as bi-stable switches, operating from nonconducting state to conducting state.

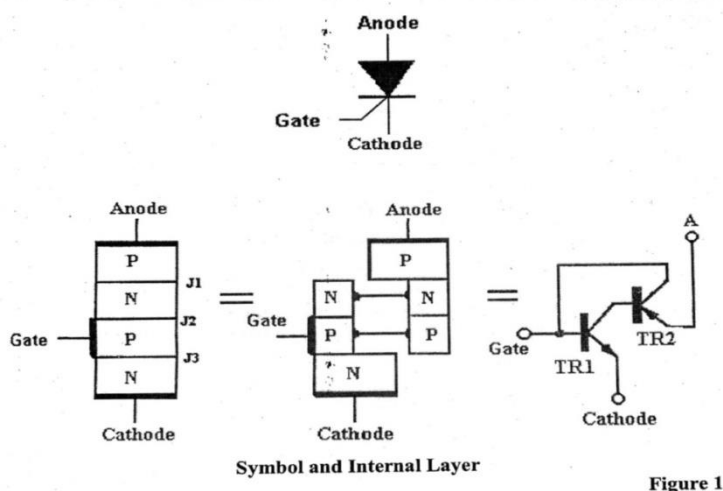

Basic three modes of operation of SCR are

1. Reverse blocking mode

Cathode is positive with respect to anode with gate open.

SCR is in reverse bias i.e. junction J1 & J3 in reverse bias j2 is in forward bias. The device act as two PN diode connected in series with reverse voltage applied across it. Small leakage current of the order of a few milli ampere or microampere flows, this is OFF state of SCR.

If reverse voltage increases, then at critical breakdown level or reverse breakdown voltage (V_{BR}) an avalanche occurs at J1 & J3 && reverse current increase rapidly, so more loss in SCR. This may lead to SCR damage because junction temperature is increasing.

Maximum working reverse voltage across SCR does not exceed V_{BR} . If applied reverse voltage across $SCR < V_{BR}$, then the device offers high impedance in reverse direction. SCR is treated as open switch.

2. Forward blocking mode (off state mode)

Anode is positive with respect to cathode with gate open.

SCR is forward bias, junction J1 & J3 is forward bias and J2 is reverse bias. Here small forward leakage current flow.

If forward voltage increases then J2 junction (rev. bias) will have avalanche breakdown called forward break over voltage (VBO).

Maximum working forward voltage across SCR does not exceed VBO. If forward voltage $< V_{BO}$; SCR offers high impedance. Hence SCR is treated as open switch even through it is forward blocking mode.

3. Forward conduction mode (on state mode)

If we want to bring SCR from forward blocking mode to forward conduction mode there are two modes.

- a. By exceeding the forward break over voltage (V_{BO})
- b. By applying gate pulse between gate and cathode.

Then SCR is in ON state and behave as closed switch.

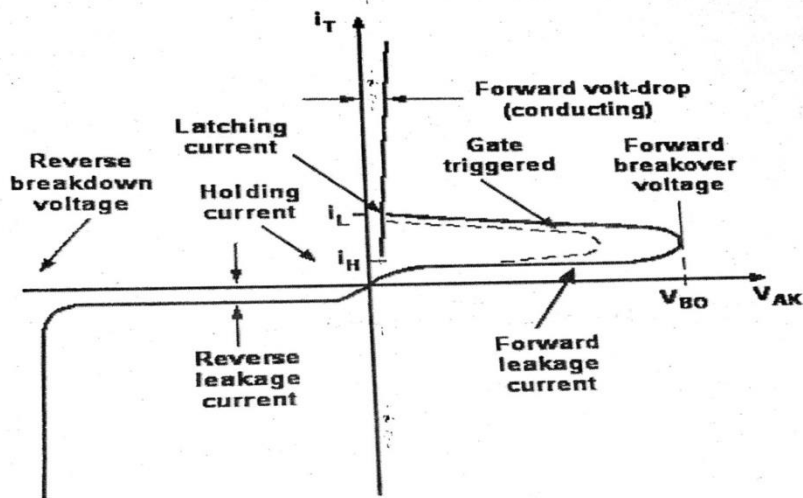

V-1 Characteristics

Figure 2

CIRCUIT DIAGRAM:-

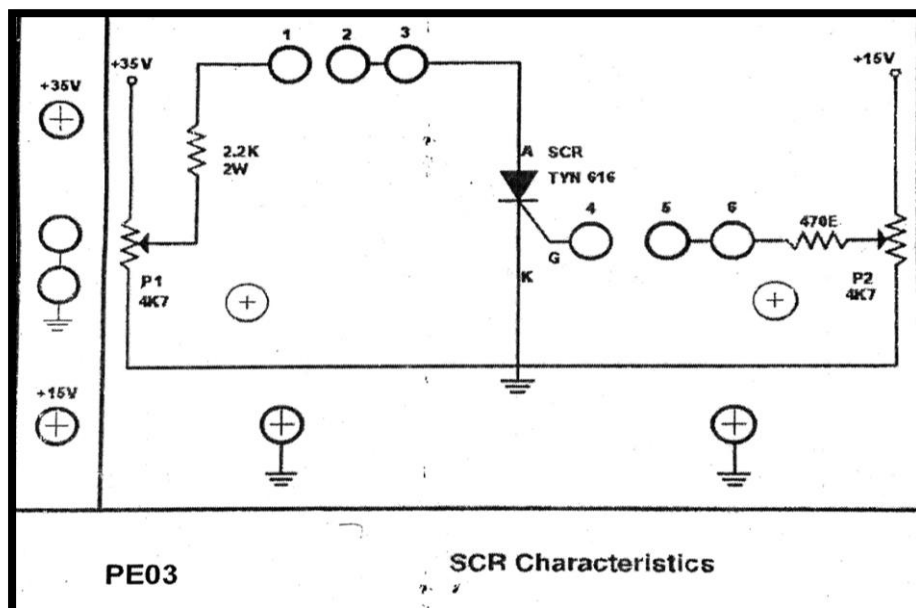

PROCEDURE:-

1. Connect +15V & +35 V DC power supplies at their indicated position from external source.
2. Rotate both the potentiometer P1 and P2 fully in counter clockwise direction connect voltmeter to point '6' & ground to read V_g and at point '3' & ground to read V_{ak} .
3. Connect ammeter at point '1' & '2' to indicate the current I_a and at point 4 & 5 to indicate the gate current I_g .
4. Switch ON the power supply.
5. Vary potentiometer P2 to set the gate current I_g to a lower value (6mA, 6.1 mA, 6.2 mA.....).
6. Increase anode voltage V_a gradually by varying potentiometer P1.
7. Observe the current I_a in the anode circuit. It shows almost zero current at the initial stage.
8. At certain point of positive anode voltage current I_a shows sudden rise in reading & voltmeter reading falls down to almost zero. This action indicates the firing of SCR.
9. If this not happen, repeat the procedure from step 5 for slightly higher value of gate current I_g .
10. Try the various value of gate current to get firing of SCR.
11. Keeping gate current constant observe precisely the firing voltage of SCR and record it in the observation table.
12. Also record the anode voltage V_a & anode current after firing of the SCR.
13. Plot the graph of V_a versus I_a .

TABULATION:-

SI NO.	Anode voltage V_a	Anode current I_a (mA) at constant value of Gate current		
		$I_g = \dots \text{mA}$	$I_g = \dots \text{mA}$	$I_g = \dots \text{mA}$
1				
2				
3				
4				
5				
6				

CONCLUSION:-

V-I characteristics of SCR is plotted on the graph which is true according to theory.

SAFETY & PRECAUTION:-

1. Keep your hand away from main supply.
2. Do not switch on the power supply unless you have checked the circuit connection as per the circuit diagram.

VIVA-VOCE QUESTION:-

1. What is SCR.
2. Application of SCR.
3. What is latching current.
4. What is holding current.
5. What is forward breakdown voltage (V_{DO})
6. What is reverse break over voltage (V_{BR})
7. Different mode of operation in SCR`

EXPERIMENT NO - 2

AIM OF THE EXPERIMENT:-

To study about the V-I characteristics of TRIAC.

OBJECTIVES:-

1. Operation of TRIAC.
2. V-I Characteristics of TRIAC.

EQUIPMENTS REQUIRED:-

1. Power Electronics board
2. D.C power supplies +15v, +35v and -35v
3. Digital Multimeter
4. 2mm patch cords

THEORY:-

The TRIAC is a three terminal semiconductor for controlling current in either direction. Below is the schematic symbol for the TRIAC shown in figure 1.

Notice the symbol looks like two SCRS in parallel (opposite direction) with one trigger or gate terminal. The main or power terminals are designed as MT1 and MT2.

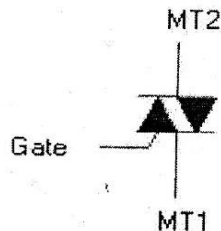

When the voltage on the MT2 is positive with regard to MT1 and a positive gate voltage is applied, the left SCR conducts. When the voltage is reversed then the right SCR conducts. Minimum holding current (I_h) must be maintained in order to keep a TRIAC conducting.

A TRIAC operate in the same way as the SCR however it operate in both a forward and reverse direction. To get a quick understanding of its operation refer to its characteristics curve below and compare this to the SCR characteristics curve. It can be triggered into conduction by either a PLUS (+) or minus (-) gate terminal.

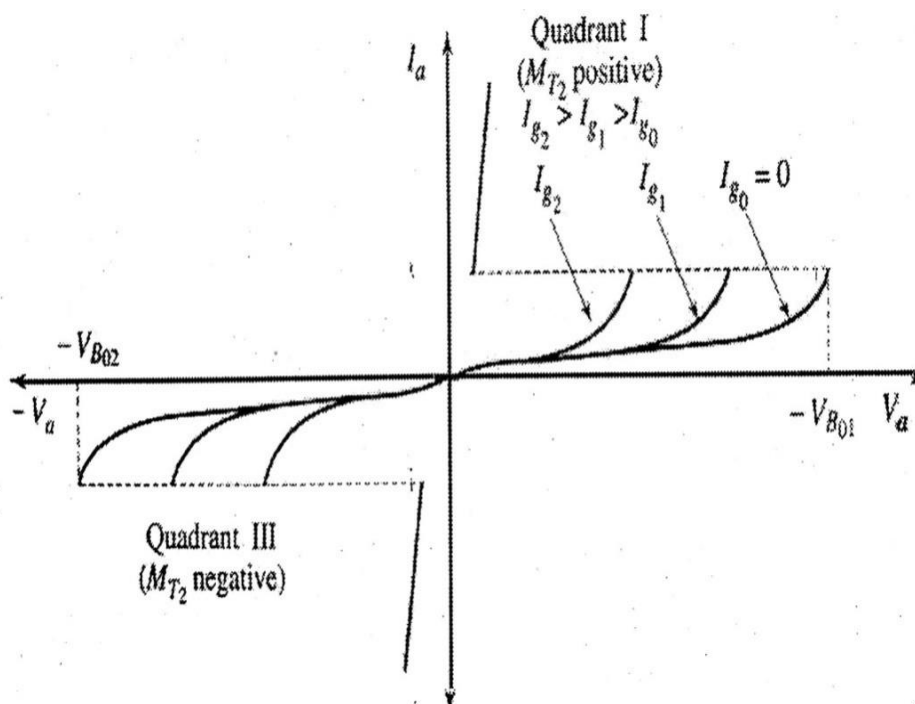

Obviously a TRIAC can also be triggered by exceeding the breakover voltage. This is not normally employed in TRIAC operation. The breakover voltage usually considered a designed limitation.

One other major limitation, as with the SCR, is dv/dt , which is the rate of rise of voltage with respect to time. A TRIAC can be switched into conduction by a large dv/dt . Typical application are in phasecontrol, Inverter design, AC switching, relay replacement, etc.

CIRCUIT DIAGRAM:-

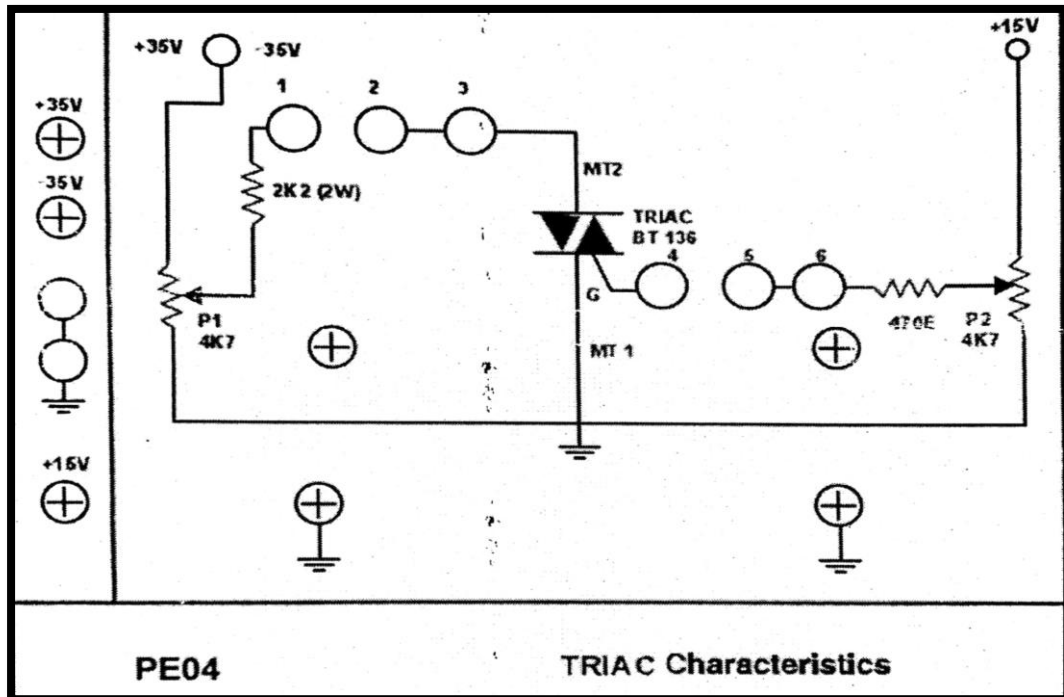

PROCEDURE:-

1. Connect +15 v, +35 v and -35 v DC power supplies at their indicates position from external power supply.
2. Rotate both the potentiometer P1 and P2 fully in counter clock wise direction.
3. Connect voltmeter between point 6 and ground to read V_g and between test point 3 and ground to read V_a .
4. Connect one ammeter between test point 1 and 2 to indicates the current I_a and other between point 4 and 5 to indicates the gate current I_g .
5. Switch on the power supply.
6. Put the switch towards +35 v.
7. Vary potentiometer P2 to set the gate current I_g to a lower value.
8. Increase anode voltage V_a gradually by varying potentiometer P1.
9. Observe the current I_a in the anode circuit, it show almost zero current at the initial stage.
10. If this not happen, repeat the procedure from step 5 slight higher value of gate current I_g
11. Try the various value of gate current to get the firing of TRIAC.
12. Also record the anode voltage V_a and anode current after firing of the TRIAC in table
13. Rotate the switch towards -35v and repeat from step 6 and note down the reading in observation table 2.
14. Plot the graph of $-V_a$ verses $-I_a$.

OBSERVATIONTABLE:-

Triac Forward Characteristics:-

SI NO.	Anode voltage V_a	Anode current I_a (mA) at constant value of Gate current (when switch is towards +35V)		
		$I_g = \dots \text{mA}$	$I_g = \dots \text{mA}$	$I_g = \dots \text{mA}$
1				
2				
3				
4				
5				
6				
7				

Triac Reverse Characteristics:-

SI NO.	Anode voltage V_a	Anode current I_a (mA) at constant value of Gate current (when switch is towards -35V)		
		$I_g = \dots \text{mA}$	$I_g = \dots \text{mA}$	$I_g = \dots \text{mA}$
1				
2				
3				
4				
5				
6				
7				

CONCLUSION:-

V-I characteristics of TRIAC is plotted on the graph which is true according to theory.

SAFETY & PRECAUTION:-

1. Keep your hand away from main supply.
2. Do not switch on the power supply unless you have checked the circuit connection as per the circuit diagram.

VIVA VOCE QUESTION:-

1. What is TRIAC ?
2. Application of TRIAC ?

EXPERIMENT NO -3

AIM OF THE EXPERIMENT:-

To study about the V-I characteristics of DIAC.

OBJECTIVES:-

1. Operation of DIAC.
2. V-I Characteristics of DIAC.

EQUIPMENTS REQUIRED:-

1. Power Electronic Board
2. DC Power supplies +35v and -35v
3. Digital multimeter
4. Patch cords

THEORY:-

The DIAC is a bidirectional trigger diode which is designed specifically to trigger a TRIAC or SCR. Basically the DIAC does not conduct (except for a small leakage current) until the breakover voltage is reached. at that point the DIAC goes into avalanche conduction also at that point the device exhibits a negative resistance characteristics and the voltage and the voltage drop across the DIAC snaps back, typically about 5volts , creating a breakover current sufficient to trigger a TRIAC or SCR.

A typical characteristics is shown in figure 1 with its schematics symbol.

DIAC is basically a two terminal parallel in-verse combination of semiconductor layer that permit trigger in either direction. The characteristics of the device clearly demonstrated that their breakdown voltage in either direction.

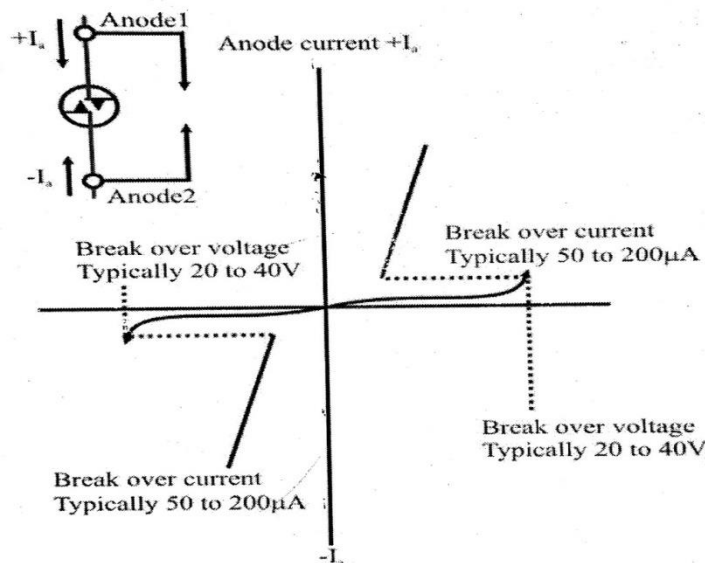

Fig-1

The basic arrangement of the semiconductor layers of the DIAC is shown in figure 2.

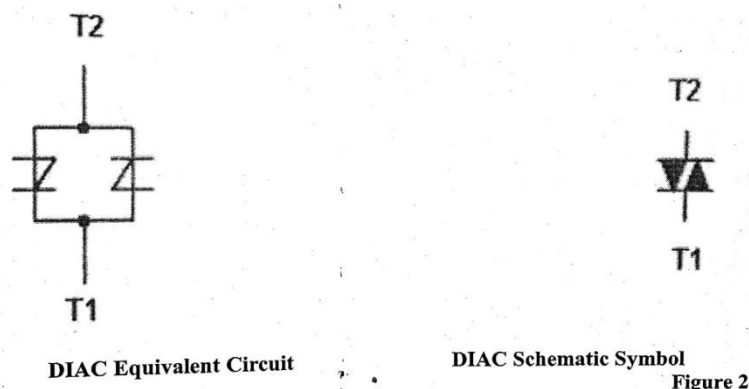

Figure 2

When T_2 is positive with respect to T_1 , the semiconductor layer of particular interest are P_1, N_2, P_2 and N_3 .

For T_1 positive with respect to T_2 the applicable layer P_2, N_2, P_1 and N_1 .

The breakdown voltage is very close magnitude but may vary from a minimum of 28V to a maximum of 42V.

They are related by the following equation.

$$VBR_1 = VBR_2 \pm 10\% VBR_2$$

The current level (IBR_1 & IBR_2) is very close in magnitude for either for each device. Both current are about 0.2 mA

CIRCUIT DIAGRAM:-

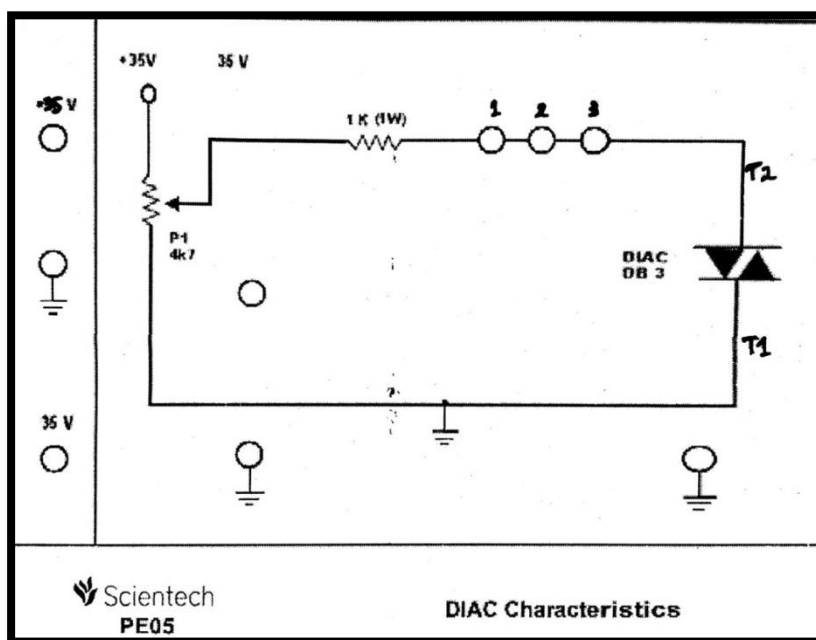

PROCEDURE:-

1. Connect +35V and -35V DC power supplies at their indicated position from external source.
2. Rotate both the potentiometer P_1 and P_2 fully in counterclockwise direction.
3. Connect voltmeter across point '3' & ground to read voltage V_a .
4. Connect ammeter between point '1' and '2' to indicate the current I_a .
5. Switch 'On' the power supply.
6. Put the switch on +35V.
7. Vary the potentiometer P_1 so as to increase the value of DIAC voltage V_a and measure the corresponding values of current I_a in an observation table.
8. Plot the curve between $+V_a$ and $+I_a$.
9. Rotate potentiometer P_1 fully in counter clockwise direction.
10. Switch off the power supply. Put the switch towards -35V.
11. Switch 'On' the power supply.
12. Vary the potentiometer P_1 so as to increase the value of DIAC voltage V_a and measure the corresponding values of current I_a in an observation table 1.
13. Plot the curve between $-V_a$ and $-I_a$.

OBSERVATION TABLE:-

Sl. NO.	DIAC Voltage +Va	DIAC Current +Ia	DIAC Voltage -Va	DIAC Current -Ia
1				
2				
3				
4				
5				
6				
7				

CONCLUSION:-

V-I characteristics of DIAC is plotted on the graph which is true according to theory.

SAFETY & PRECAUTION-

1. Keep your hand away from main supply.
2. Do not switch on the power supply unless you have checked the circuit connection as per the circuit diagram.

VIVA VOCE QUESTION:-

1. What is DIAC?
2. Application of DIAC?

EXPERIMENT NO -4

AIM OF THE EXPERIMENT:-

To study about drive circuit for SCR & TRIAC using DIAC.

OBJECTIVE:-

1. Operation of SCR.
2. Operation of TRIAC.

EQUIPMENTS REQUIRED:-

1. Power Electronic Board
2. 40 watts Bulb
3. Digital multimeter
4. Patch cords

THEORY:-

The major thrust of thyristor technology has been in the field of industrial process control. In almost every process the old magnetic control methods have been replaced by more accurate, dependable, faster and economical thyristor control methods. Some of the important process controls such as temperature, pressure, Position, humidity, level, illumination, static excitation of alternator, etc. have been made very effective by using solid state devices, specially thyristor. The intensity of illumination of a lighting system can be controlled simply by the rheostatic method of control. It is a manual method and has the disadvantage of undesired power loss across the resistor. Solid state method of illumination control is much more effective and efficient as compared to the rheostatic method of control. The power loss caused in a solid state circuit is almost negligible and a smooth control of illumination is possible. Illumination controllers can also be made automatic using solid state devices. Such circuits are widely used for automatic stage lighting. Solid state dimmer circuit can be fabricated using SCRS and Diac-Triac. They are also cheaper than using rheostats or dimmer state. The intensity of illumination of a source can be varied over a wide range by using a SCR & TRIAC.

CIRCUIT DIAGRAM:-

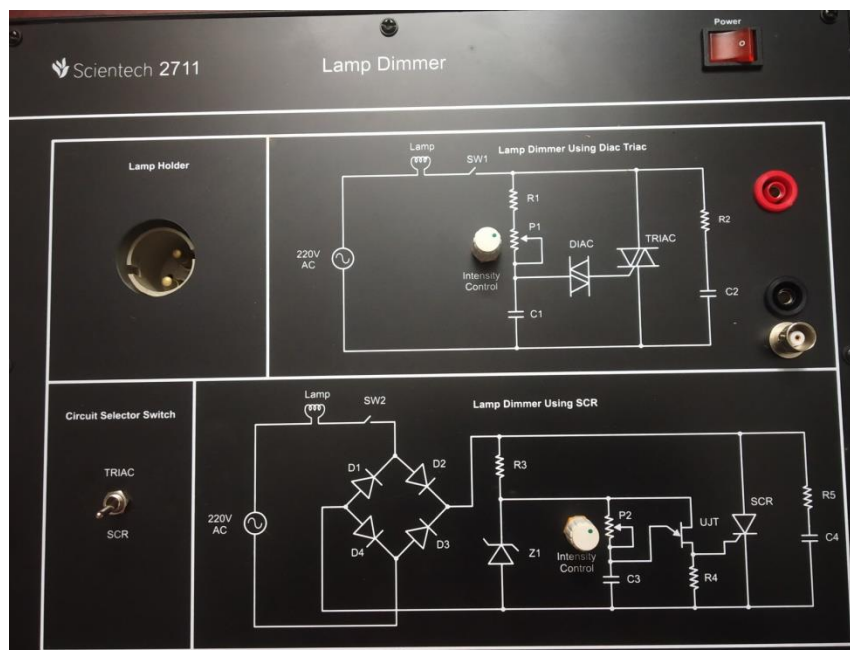

PROCEDURE:-

1. Study the circuit configuration given on the front panel carefully.
2. Mount 40 watts bulb in bulb holder mounted on the front panel.
3. Switch ON the main power supply and move the toggle switch towards the provided on the front panel.
4. Now vary the knob of intensity control & observe the corresponding effect on the intensity of light.

CONCLUSION:-

From the above experiment we know about the drive circuit for SCR & TRIAC using DIAC.

SAFETY & PRECAUTION:-

1. Keep your hand away from main supply.
2. Do not switch on the power supply unless you have checked the circuit connection as per the circuit diagram.

VIVAVOCE QUESTION:-

1. What is DIAC
2. Application of DIAC

EXPERIMENT NO -5

AIM OF THE EXPERIMENT:-

To study about drive circuit for SCR & TRIAC using UJT.

OBJECTIVE:-

1. Operation and design of UJT.
2. Difference between natural and forced commutation.

EQUIPMENTS REQUIRED:-

1. Power Electronic Board
2. CRO.30 MHz, Dual channel,2 trace
3. Digital multimeter
4. Patch cords
5. Stop watch

THEORY:-

Many techniques are used for triggering an SCR. A low power source may cause erratic SCR triggering where as a highpower source ensuring consistent SCR turn ON, may overheat the gate and cause it to burn out. An ideal solution would suggest triggering. The SCR with sharp , high powered pulses of short duration , whose peak and average power do not exceed the power capacities of the SCR gate for which they are intended the unijunction transistor (UJT) is frequently employed as a trigger source,because it can generate the required pulses. The UJT connected as a relaxation oscillator generates a voltage waveform across B1 which is applied as a triggering pulse to an SCR gate to turn on the SCR. Whenpower is applied to the circuit capacitor (C)starts charging exponentially through R to the applied voltage. The voltage across C is the voltage V_E applied to the emitter of the UJT. when C is charged to the peak point voltage of the UJT, the UJT is turned ON,decreasing greatly the effective resistance R_{B1} (internal).

CIRCUIT DIAGRAM:-

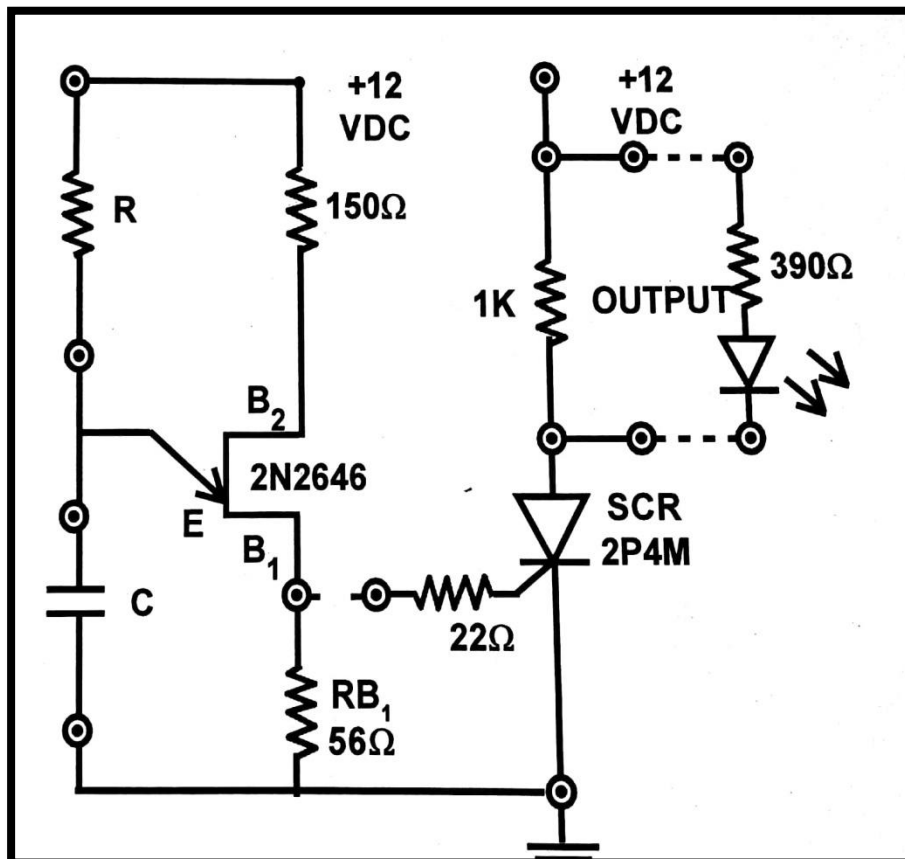

PROCEDURE FOR SCR WITH UJT FIRING:-

1. Connect the circuit by connecting dotted lines through patch cords i.e, connect B₁ of UJT to one end of 22Ω resistance connected at the gate of SCR & connect the output to output indicator (LED).
2. Switch ON the instrument using ON/OFF toggle switch provided on the front panel.
3. Select any value of R&C and observe the output status on LED when it glows. Note down the time period when the LED glows and compare it with calculate time period i.e

$$T = RC \ln 1/(1-\eta)$$

Where ln=natural log

η for UJT=0.72 from reverse calculation (In general it varies from 0.51 to 0.8)

Value of R is in ohm (To convert R in ohm multiple KΩ by 10³)

Value of C in farad (To convert C in farad μf multiple by 10⁻⁶)

4. Change the value of R&C and note down different time period observation.
5. To check the wave shape across C & RB₁ (56Ω) resistance connect CRO across these point and check wave shape (Across resistance you will get spikes after specified/observed time and across capacitor sawtooth wave).
6. To check the output on CRO across output resistance (1kΩ). Set the mode of CRO to DC and repeat step 1 to 4, when SCR turn on DC level on CRO shifts.

OBSERVATION TABLE:-

SI. NO	Resistance (kΩ)	Capacitor (μF)	Time(Sec.)	
			calculated	observed
1				
2				
3				
4				
5				
6				

MATHEMATCAL CALCULATION:-

When R = 200KΩ = 200×10³
C=100 Mf = 100× 10⁻⁶ farad

Formula used to calculate Time period

$$T = RC \ln (1/1-\eta) \text{ (where ln=natural log)-----(i)}$$

Slove the equation ln (1/1-η) (where η=eta)
 =2.3026log₁₀(1/1-η)(ln=2.3026log₁₀)
 =2.3026log₁₀(1/1-0.72)(because η=0.72, standard value for UJT)
 =2.3026log₁₀(3.57)(because log₁₀3.57=0.552)
 =2.3026 ×0.552
 =1.27

Now put the value of ln (1/1-η) in equation(i) and also put the value of R& C

SO T= 200×10³ ×100×10⁻⁶ ×1.27

T=200×10³ ×100×10⁻⁶ ×1.27/10⁻⁶

T=200×100×1.27/1000

T=20×1.27

T=25.4 second

To calculate the time period for any value of R & C. Put the value of R & C in equation (i) and value of ln (1/1-η)=1.27

CONCLUSION:-

From the above experiment we know about the drive circuit for SCR & TRIAC using UJT.

SAFETY & PRECAUTION-

1. Keep your handaway from main supply.
2. Do not switch on the power supply unless you have checked the circuit connection as per the circuit diagram.

VIVAVOCE QUESTION:-

1. What is the use of pulse transformer.
2. Why UJT triggering circuit is superior as compared to R and RC triggering circuit.
3. Why do we require turn-on circuit for Thyristor.
4. Why do we require turn-off circuit for Thyristor.

EXPERIMENT NO -6

AIM OF THE EXPERIMENT:-

Study of single phase half wave controlled rectifier with resistive (R) load.

OBJECTIVES:-

1. Operation of half wave controlled rectifier.
2. Analyse the effect of change in firing angle on output Voltage waveform.
3. Difference among uncontrolled, half controlled and fully controlled rectifier.

EQUIPMENTS REQUIRED:-

1. AC Power electronics board.
2. Oscilloscope
3. 2mm patch cord
4. Multi meter

THEORY:-

Rectification is a process of converting an alternating current or voltage into a direct current or voltage. Rectifier circuits are classified into three classes: 1. Uncontrolled 2. Half Controlled. 3. Fully Controlled

A uncontrolled converter/rectifier uses only diodes and the level of dc output voltage cannot be controlled. A half-controlled converter or semi-converter uses a mixture of diodes and thyristor and there is a limited control over the level of DC output voltage. A fully controlled converter uses thyristors only and there is a wider control over the level of DC output voltage.

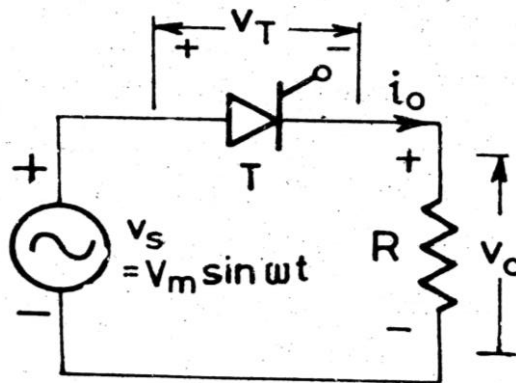
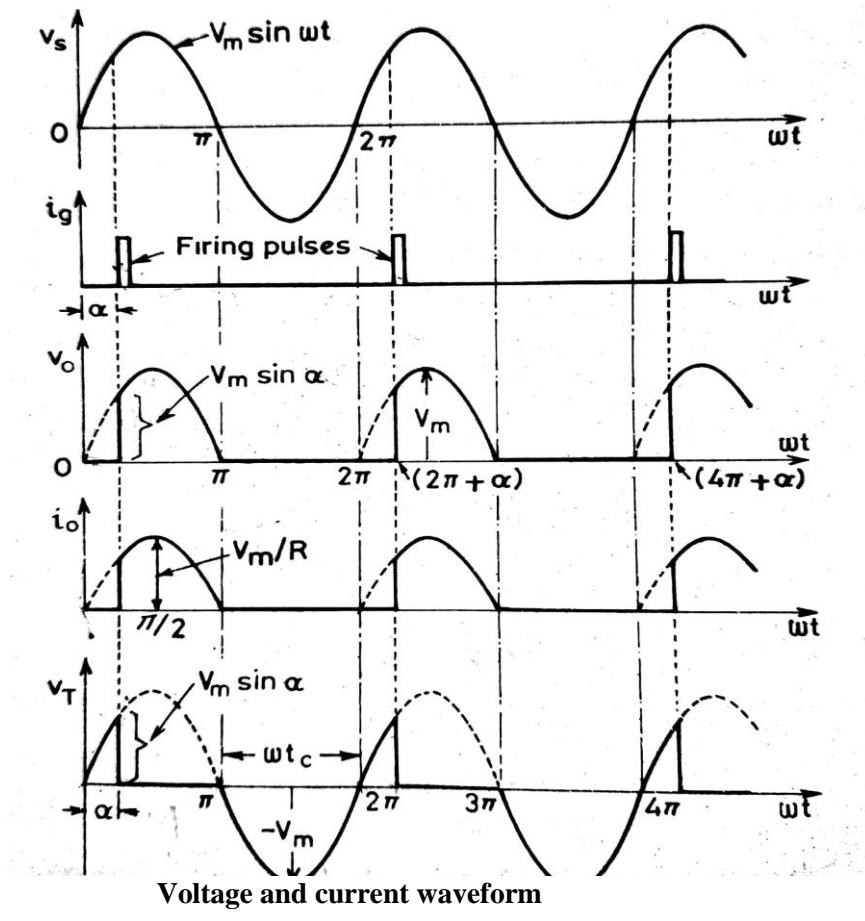

Fig. 1

Single phase half-wave thyristor circuit with R load

The circuit is energised by line voltage or transformer secondary voltage i.e $E = E_m \sin \omega t$. During the positive half cycle of the supply voltage the thyristor anode is positive with respect to its cathode and until the thyristor is triggered by a proper gate pulse it blocks the flow of load current in the forward direction. When the thyristor is fired at an angle ' α ' the supply voltage is applied to the load. The load current will flow until it is commutated by reversal of supply voltage at $\omega t = \pi$. The angle $\pi - \alpha = \beta$ during which the thyristor conducts is called as conduction angle.



CIRCUIT DIAGRAM:-

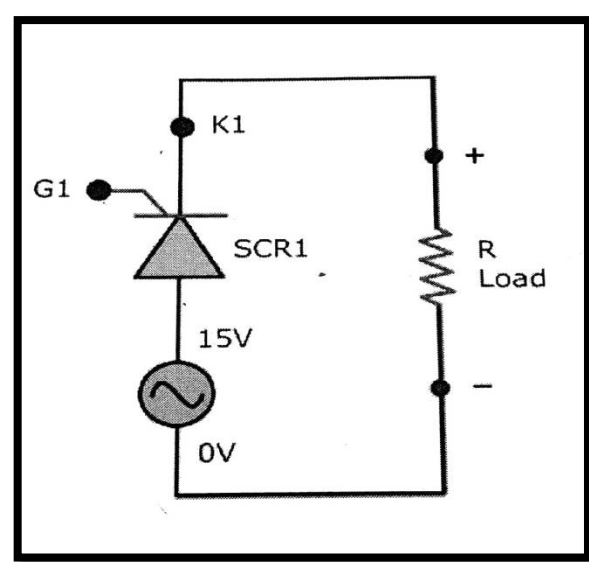

Fig-1

PROCEDURE:-

1. Rotate the firing control potentiometer in full clockwise direction.
2. Switch 'On' the power.
3. Measure the AC voltage (V_{rms}) by voltmeter between point 0V-15 V and calculate E_m by $E_m=1.414 \times V_{rms}$.
4. Switch 'Off' the power.
5. Use SCR1 from SCR assembly and to construct single phase half wave controlled rectifier configuration using 2 mm patch cord.
6. Connect 15V point from AC source section to anode of SCR1.
7. Connect the one terminal of load resistor (point 6) to cathode terminal of SCR1 and other terminal of load resistor (point 7) is connect to 0V terminal of 15V supply at AC source section.
8. Connect the gate pulse G1 at gate (G) of SCR1 and connect K1 at cathode of SCR1 from TCA785 firing circuit section.
9. Verify the connection before switch on the power.
10. Connect the circuit of half wave rectifier as shown in figure 1 using 2 mm patch cords.
11. Switch 'On' the power.
12. Connect the oscilloscope and voltmeter across the load.
13. Vary the firing control potentiometer and set on $0^\circ, 18^\circ, 36^\circ, 54^\circ, 72^\circ, 90^\circ, 108^\circ, 126^\circ$ and 162° firing angle using equation.
14. Observe the output waveforms and note the reading of voltages across load on different firing angles.
15. Calculate the load current I_{DC} and load power P_{DC} from measured load voltage V_o .

TABULATION:-

SI NO.	E_m in (volt)	Time period T in (ms)	Firing angle in ($^\circ$)	$\cos\alpha$	Measured output RMS DC voltage in (volt)	Calculate output DC voltage in (volt) $V_{dc} = \frac{E_m}{2\pi} (1 + \cos\alpha)$	Measured load current in (mA)	Load resistance in (k Ω)	Output power load in (watt) $P=V \times I$
1									
2									
3									
4									
5									

CONCLUSION:-

The operation of single phase half -wave controlled rectifier using 'R' load has been studied and the output wave forms has been observed for different firing angles which is true according to the theory.

SAFETY & PRECAUTION:-

1. Set all the switches to the OFF position.
2. To switch ON and OFF the supply voltage correct sequence.
3. Performed the experiment with supply voltage less than 55 V for resistive load.
4. Observe the output waveforms carefully on the CRO

VIVA VOCE QUESTION:-

1. What is rectifier?
2. What is half controlled and fully controlled rectifier?
3. What is conduction angle?
4. What is extinction angle?
5. What is natural or line commutation?

EXPERIMENT NO -7

AIM OF THE EXPERIMENT:-

Study of single phase full wave controlled rectifier (mid-point configuration) with resistive load.

OBJECTIVES:-

1. Operation of full wave controlled rectifier.
2. Effect of change in firing angle on output Voltage waveform.

EQUIPMENTS REQUIRED:-

5. Power electronics board.
6. Oscilloscope
7. 2mm patch cord
8. Multi meter

THEORY:-

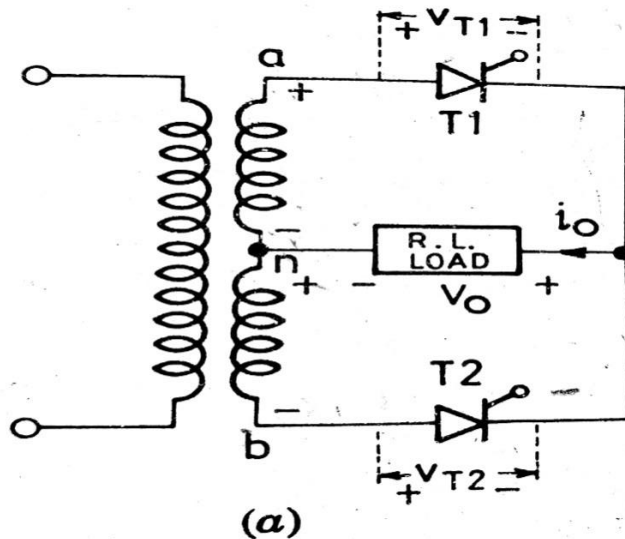

This type of full wave rectifier uses two SCRS connected to the centre tapped secondary of a transformer. During the +ve half cycle when terminal 'a' of the transformer is positive with respect to terminal 'n', the SCR1 is forward biased. When the SCR1 is triggered at a firing angle ' α ' current would flow through the path a-T1-R-n.

This current continues to flow upto angle π when the line voltage reverses its polarity will change and SCR1 is turned off. During the -ve half cycle of AC supply the terminal 'b' of the transformer is +ve with respect to the terminal 'n' and SCR2 is forward biased.

When the SCR2 is triggered at an angle $\pi + \alpha$, the current flow through the path b-T2-R-n. This current continues to flow till angle 2π then the SCR2 is off. Hence both the thyristors are triggered with same firing angle and hence they share the load current equally.

CIRCUIT DIAGRAM:-

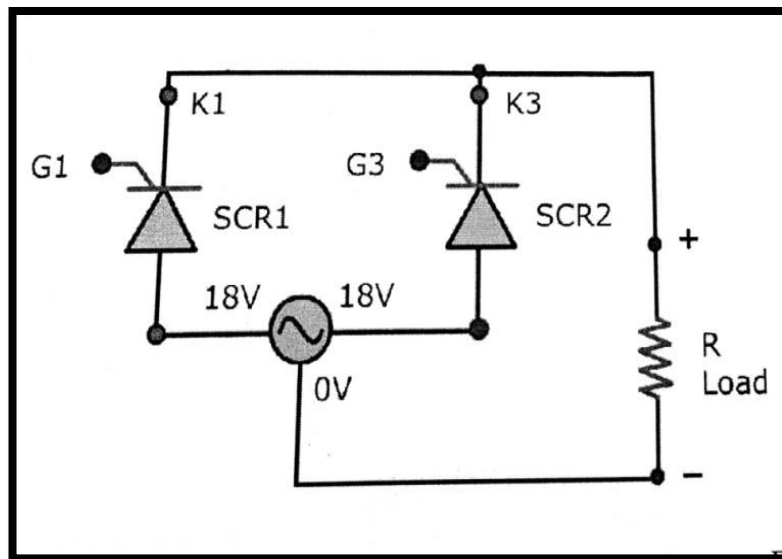

PROCEDURE:-

1. Rotate the firing control potentiometer in fully clockwise direction.
2. Switch 'On' the supply.
3. Measure the AC voltage (V_{rms}) by voltmeter between point 0V-18V and calculate E_m by $E_m = 1.414 \times V_{rms}$.
4. Switch 'Off' the power.
5. Use SCR1 and SCR2 from SCR assembly and construct single phase full wave controlled rectifier configuration using 2 mm patch cord.
6. Connect 18V point from AC source section to anode of SCR1.
7. Connect another 18V point from AC source section to anode SCR2.
8. Connect cathode of SCR1 to cathode of SCR2.
9. Connect one terminal of load resistor (point 6) to common cathode terminal of SCR1 and SCR 2 and other terminal of load resistor (point 7) is connect 0V terminal of 18V supply at AC source section.
10. Connect gate pulse G1 at gate (G) of SCR and connect K1 at cathode of SCR1 from TCA785 firing circuit section.
11. Connect gate pulse G3 at gate (G) of SCR2 and connect K3 at cathode of SCR2 from TCA785 firing circuit section.
12. Verify the connection before switch on the power.
13. Switch 'On' the power.
14. Connect the circuit of full wave controlled rectifier (mid-point configuration) as shown figure 1 using 2 mm patch cords.
15. Switch 'On' the power.
16. Connect the oscilloscope and voltmeter across the load.
17. Vary the firing control potentiometer and set on 18° , 36° , 54° , 72° , 90° , 126° and 162° firing angle using equation .
18. Observe the output waveforms and note the reading of voltage across load on different firing angle
19. Calculate the load current I_{DC} and power P_{DC} from measured load voltage V_o .

OBSERVATION TABLE:-

Sl. no.	E_m in (volt)	Time period T in (ms)	Firing angle in ($^{\circ}$)	$\text{Cos}\alpha$	Measured output RMS DC voltage in (volt)	Calculated output DC voltage in (volt) $V_{dc} = \frac{E_m}{\pi} (1 + \text{Cos}\alpha)$	Measured load current in (mA)	Load resistance in ($K\Omega$)	Output power load in (watt) $P = V \times I$
1									
2									
3									
4									
5									

FIRING ANGLE CALCULATION:-

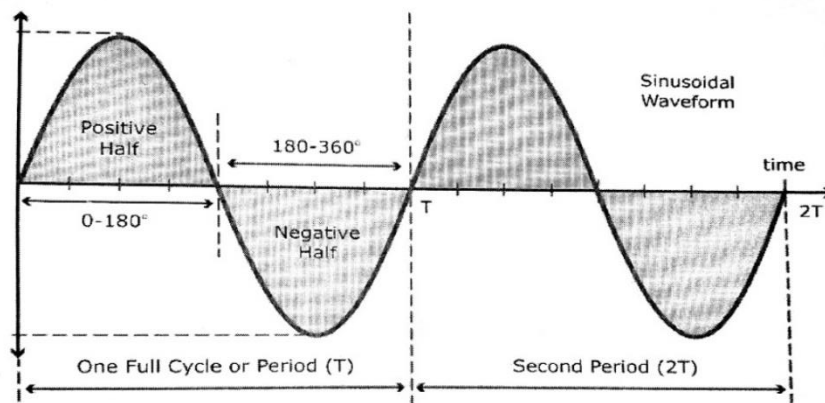

Frequency of Sine wave is 50 Hz

T=Time period F=Frequency

$$T = \frac{1}{f} \quad f = \frac{1}{T}$$

50Hz is equal to 20 ms & 20 ms is equal to 360⁰

So, 10ms is equal to 180⁰ & 1ms is equal to 18

AC voltage value $E_m = 1.414 \times V_{rms}$

Here V_{rms} is 15V and 18V reading on multimeter

Firing angle $\alpha = (180 \times T) / 10 \text{ ms}$

Output DC voltage $V_{dc} = \frac{E_m}{\pi} (1 + \text{cos}\alpha)$

Output DC power $P_{dc} = V_{dc} \times I_{dc}$

CONCLUSION:-

The operation of single phase full wave controlled rectifier using 'R' load has been studied and the output wave forms has been observed for different firing angles which are true according to the theory.

SAFETY & PRECAUTION:-

1. Set all the switches to the OFF position.
2. To switch ON and OFF the supply voltage correct sequence.
3. Performed the experiment with supply voltage less than 55 V for resistive load.
4. Observe the output waveforms carefully on the CRO.

VIVAVOCE QUESTION:-

1. What is the difference between half wave and full wave Rectifier.

EXPERIMENT NO -8

AIM OF THE EXPERIMENT:-

Study of single phase full wave controlled bridge rectifier with resistive (R) load.

OBJECTIVE:-

1. Operation of fullwave controlled bridge rectifier.
2. Effect of different load on waveform.

EQUIPMENTS REQUIRED:-

1. Power electronics board.
2. Oscilloscope
3. 2mm patch cord
4. Multi meter

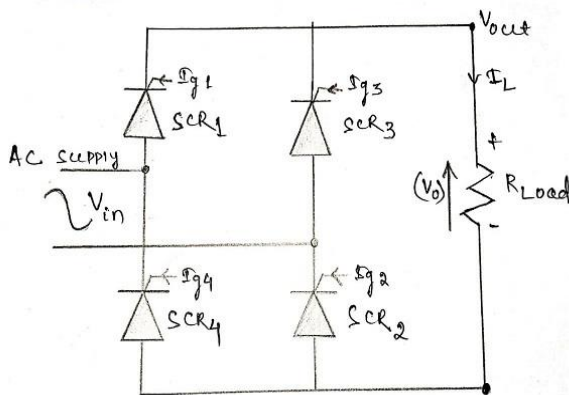

THEORY:-

During the positive half cycle thyristor T1 and T2 are forward biased and if they are triggered simultaneously then the current flows through the line L-T1-R-T2-N.

Hence during the positive half cycle thyristor T1 and T2 are conducting in nature. during the negative half cycle thyristor T3 and T4 are forward biased and if they are triggered simultaneously then the current will flow the path N-T3-R-T4-L. Hence during negative half cycle T3 and T2 are conducting in nature.

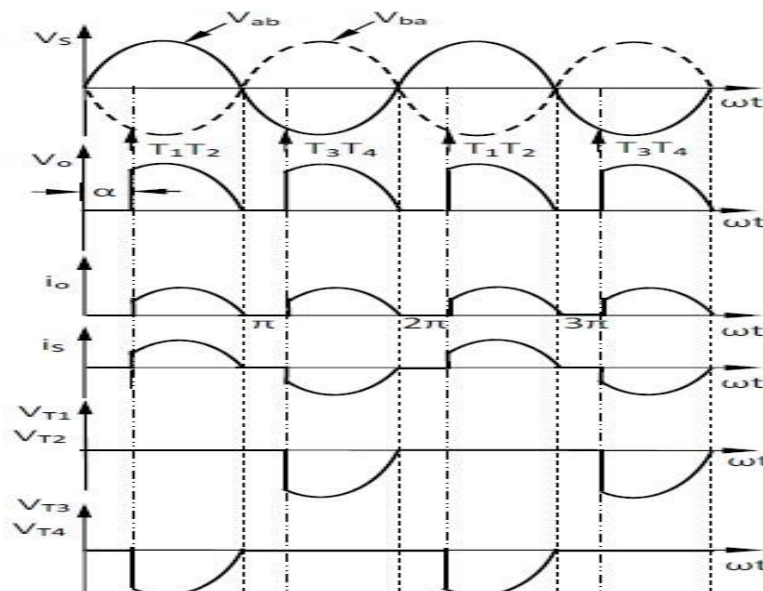

CIRCUIT DIAGRAM:-

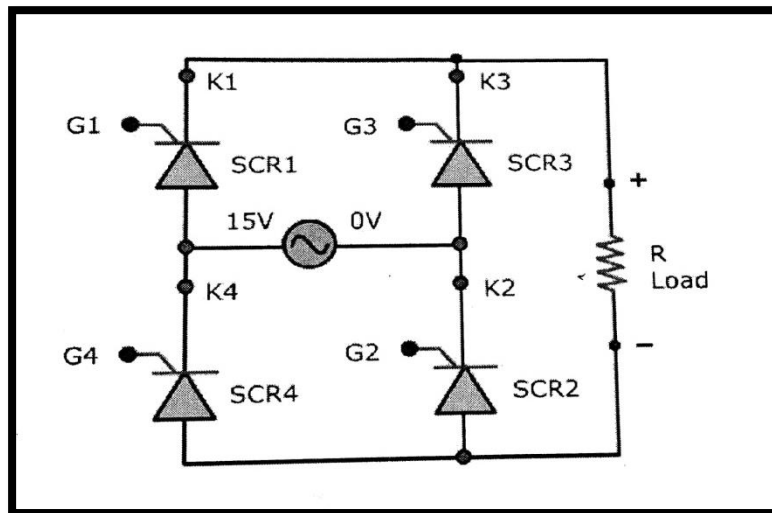

PROCEDURE:-

1. Rotate the firing control potentiometer in full clockwise direction.
2. Switch on the supply.
3. Measure the AC voltage (V_{rms}) by voltmeter between point 0V-15V and calculate E_m by $E_m = 1.414 \times V_{rms}$.
4. Switch off the power.
5. Use SCR1, SCR2, SCR3 and SCR4 from SCR assembly and to construct single phase fully controlled bridge rectifier configuration using 2 mm patch cord.
6. Connect cathode of SCR1 to cathode of SCR3 and connect anode of SCR2 to anode of SCR4.
7. Connect cathode of SCR4 to anode of SCR1 and connect cathode of SCR2 to anode of SCR3.
8. Connect one terminal of load resistor (point 6) to common cathode terminal of SCR1 and SCR3 and other terminal of load resistor (point 7) is connect to common anode terminal of SCR2 and SCR 4.
9. Connect gate pulse G1 at gate (G) of SCR1 and connect K1 at cathode of SCR1 from TCA785 IC firing circuit section.
10. Connect gate pulse G2 at gate (G) of SCR2 and connect K2 at cathode of SCR2 from TCA685 IC firing circuit section.
11. Connect gate pulse G3 at gate (G) of SCR3 and connect K3 at cathode of SCR3 from TCA785 IC firing circuit section.
12. Connect gate pulse G4 at gate (G) of SCR4 and connect K4 at cathode of SCR4 from TCA785 IC firing circuit section.
13. Connect 15V point from AC source section to anode of SCR1 or cathode of SCR4 and connect 0V point of 15V supply from AC source section to anode of SCR3 or cathode of SCR2 .
14. Verify the connection before switch on the power.
15. Switch 'On' the power.
16. Connect the oscilloscope and voltmeter across the load.
17. Vary the firing control potentiometer and set on 0° , 18° , 36° , 54° , 72° , 90° , 108° , 126° and 162° firing angle using equation.
18. Observe the output wave forms and note the reading of voltmeter across load on different firing angle.
19. Calculate the load current I_{Dc} and power P_{Dc} from measured load voltage V_o .

TABULATION:-

Sl. no.	E_m in (volt)	Time period T in (ms)	Firing angle in ($^{\circ}$)	$\text{Cos}\alpha$	Measured output RMS DC voltage in (volt)	Calculated output DC voltage in (volt) $V_{dc} = \frac{E_m}{\pi} (1 + \text{Cos}\alpha)$	Measured load current in (mA)	Load resistance in ($K\Omega$)	Output power load in (watt) $P = V \times I$
<u>1</u>									
<u>2</u>									
<u>3</u>									
<u>4</u>									
<u>5</u>									

FIRING ANGLE CALCULATION:-

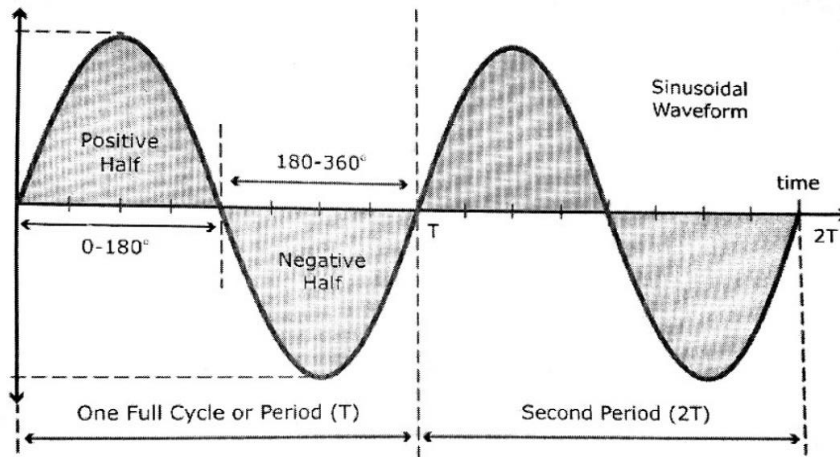

Frequency of Sine wave is 50 Hz

T=Time period F=Frequency

$$T = \frac{1}{f} \quad f = \frac{1}{T}$$

50Hz is equal to 20 ms & 20 ms is equal to 360°

So, 10ms is equal to 180° & 1ms is equal to 18°

AC voltage value $E_m = 1.414 \times V_{rms}$

Here V_{rms} is 15V and 18V reading on multimeter

Firing angle $\alpha = (180 \times T) / 10 \text{ ms}$

Output DC voltage $V_{dc} = \frac{E_m}{\pi} (1 + \text{cos}\alpha)$

Output DC power $P_{dc} = V_{dc} \times I_{dc}$

CONCLUSION:-

The operation of single phase full wave controlled rectifier using 'R' load has been studied and the output wave form has been observed for different firing angles which are true according to the theory.

SAFETY & PRECAUTION:-

1. Set all the switches to the OFF position.
2. To switch ON and OFF the supply voltage correct sequence.
3. Observe the output waveforms carefully on the CRO

VIVA VOCE QUESTION:-

1. What will happen if the firing angle is greater than 90° .
2. State the type of commutation used in this circuit.
3. What is the commutation angle of a Rectifier?

EXPERIMENT NO -9

AIM OF THE EXPERIMENT:-

To study of working of series inverter.

OBJECTIVES:-

1. Operation of series inverter
- 2.

EQUIPMENTS REQUIRED:-

1. Power electronics board.
2. Oscilloscope
3. 2mm patch cord
4. Multi meter

THEORY:-

This circuit which converts DC power into AC power is called inverter. If the thyristors commutation circuit of the inverter is in series with the load, then the inverter is called series inverter. In this circuit, it is possible to turn-on thyristor T1 before the current through thyristor T2 has become zero and vice-versa. Moreover, the modified series inverter given in below figure can be operated beyond the resonance frequency (f_r) of the circuit. The inverter's resonance frequency depends on the values of L, R and C in the circuit.

CIRCUIT DIAGRAM:-

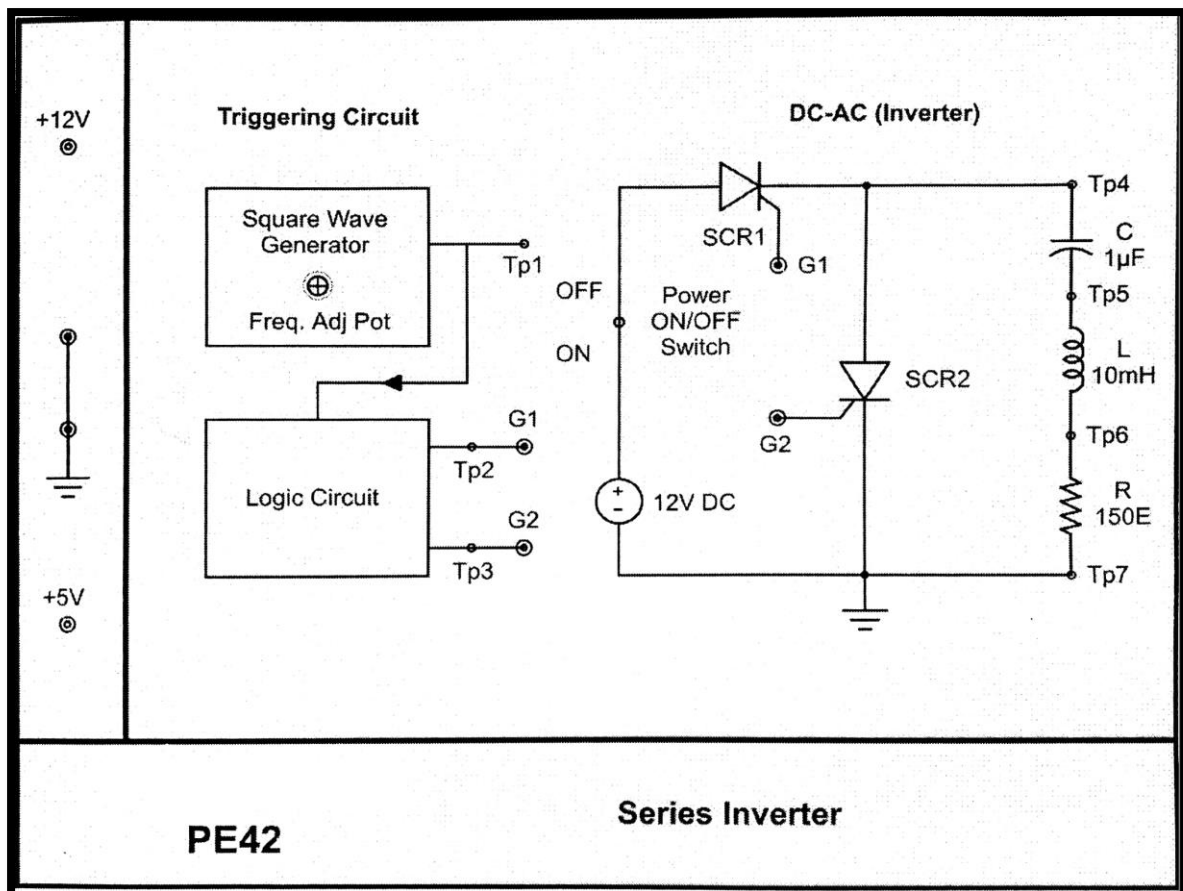

PROCEDURE:-

1. Connect +5V DC power supply at their indicated position from external source.
2. Rotate the potentiometer P1 fully in counter clockwise in direction.
3. Switch on the power supply. set the frequency of the pulse by varying the potentiometer.
4. Observe the frequency and amplitude of the pulse test point Tp1 and Tp2.
5. And now, connect the point G1 to G1 and G2 to G2 to the respective gate terminal of the SCR.
6. Now, switch on the power on/off switch.
7. Records & observe the output waveform across the load.
8. Compare the output waveform with the model waveform as shown in figure 2.
9. Repeat the experiments by changing the gate pulse frequency. By varying the potentiometer P1 the gate pulse frequency can be varied and plot the output waveforms.

TABULATION:-

SI. NO.	Gate pulse G1		Gate pulse G2		Gate pulse G3	
	Amplitude (V)	Frequency (HZ)	Amplitude (V)	Frequency (HZ)	Amplitude (V)	Frequency (HZ)
1						
2						
3						
4						
5						

CONCLUSION:-

The operation of series inverter has been studied and the output wave form has been observed which is true according to the theory.

SAFETY & PRECAUTION:-

1. Keep your hand away from main supply.
2. Do not switch on the power supply unless you have checked the circuit connection as per the circuit diagram.

VIVA VOCE QUESTION:-

1. Why the circuit is called series inverter?
2. What is the type of commutation for series inverter?
3. What is the principle of series inverter?
4. Disadvantage of series inverter?

EXPERIMENT NO -10

AIM OF THE EXPERIMENT:-

To study about the single phase cyclo converter (Mid-point type Step-down Cyclo converter).

OBJECTIVES:-

1. Working of cyclo converter.

EQUIPMENTS REQUIRED:-

1. Cyclo converter kit
2. Oscilloscope
3. 2 mm patch cords.
4. Multimeter.

THEORY:-

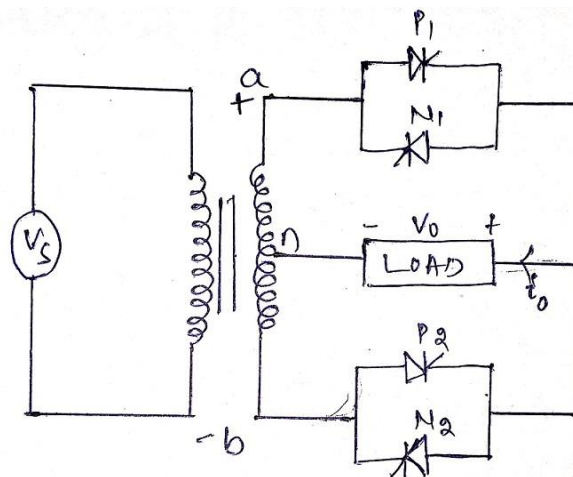

P1 and P2 are positive group SCRs accommodated to conduct the load current in the forward direction. N1 and N2 are negative groups SCRs accommodated to conduct the load current in the reverse direction. During the positive half of the supply voltage 'a' is positive w.r.t to 'b' and when P1 is triggered at angle ' α ', then current will flow through the path $a^+ - P1 - \text{load} - n^-$. It develops a positive envelope of output voltage. During the negative half of the supply voltage, 'b' is positive w.r.t to 'a', when P2 is triggered at angle $\pi + \alpha$, then current will flow through the path $b^+ - P2 - \text{load} - n^-$. It will develop a positive envelope of output voltage.

Again during the positive supply of input voltage, 'a' is positive w.r.t 'b'. Under this condition, forward biased N2 is triggered at angle $2\pi + \alpha$, then current will flow through the path $n^+ - \text{load} - N2 - b^-$. N2 will conduct up to 3π and naturally commutated at 3π . In this way it will develop a negative envelope of output voltage. Again during the negative supply of input voltage, 'b' is positive w.r.t 'a'. Under this condition, forward biased N1 is triggered at angle $3\pi + \alpha$, then output current will flow through the path $n^+ - \text{load} - N1 - a^-$. N1 will conduct up to 4π and naturally commutated at 4π . In this way it will develop a negative envelope of output voltage.

In this way P1 and P2 form '2' positive envelope in every half cycle and N1 and N2 form a negative envelope sequentially in every half cycle.

Therefore output frequency of voltage and current has been step-down to two-times of supply frequency.

$$f_o = \frac{1}{2}(f_s)$$

where f_o = output frequency
 f_s = Supply frequency

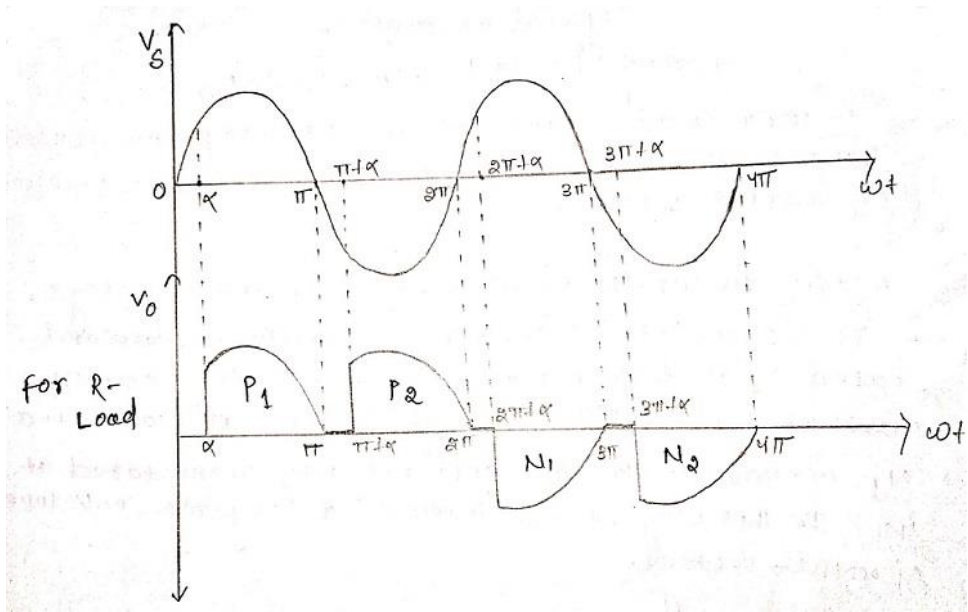

Wave form for R-Load

CIRCUIT DIAGRAM:-

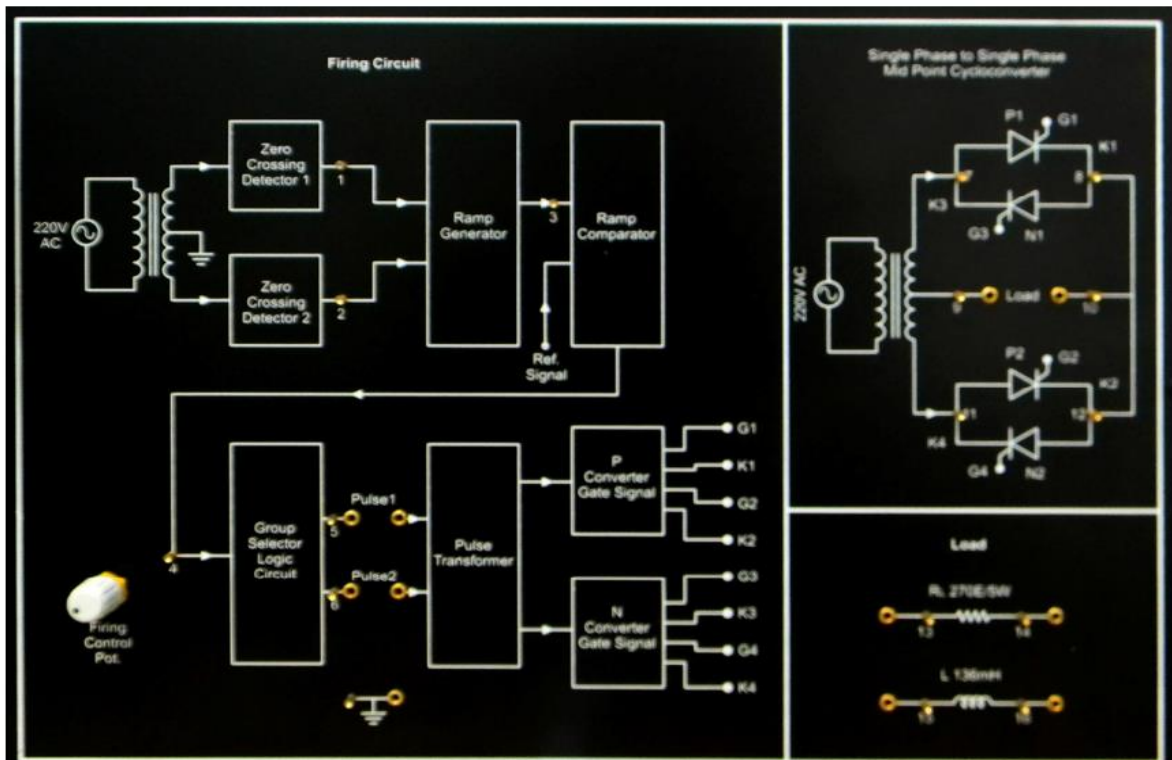

PROCEDURE:-

1. Connect the two pin mains lead to the main power supply.
2. Connect the R-Load across the load point.
3. Switch ON the instrument.
4. Now connect the load to the CRO to see the waveform of the output voltage.
5. From this CRO display trace the waveform of output voltage for different firing angle i.e 18° , 36° , 54° , 72° .

OBSERVATIONTABLE:-

SI. NO.	Firing Angle (in $^{\circ}$)	Voltage Across Load (in Volt)
1	18°	
2	36°	
3	54°	
4	72°	
5	90°	

CONCLUSION:-

From this experiment we found that by varying the firing angle of cycloconverter firing circuit the wave form of output voltage across the load changes simultaneously.

SAFETY & PRECAUTION:-

1. Keep your hand away from main supply.
2. Do not switch on the power supply unless you have checked the circuit connection as per the circuit diagram.

VIVAVOCE QUESTION:-

1. What is cycloconverter
2. Application of cycloconverter.

EXPERIMENT NO -11

AIM OF THE EXPERIMENT:-

To perform the speed control of DC motor using Chopper. (IGBT based Step Down chopper)

OBJECTIVES:-

2. Working of step-down chopper.
3. Speed control of DC Motor by using step -down chopper.

EQUIPMENTS REQUIRED:-

1. Oscilloscope
2. Multimeter
3. Step Down Chopper Kit.
4. Patch Cords

THEORY:-

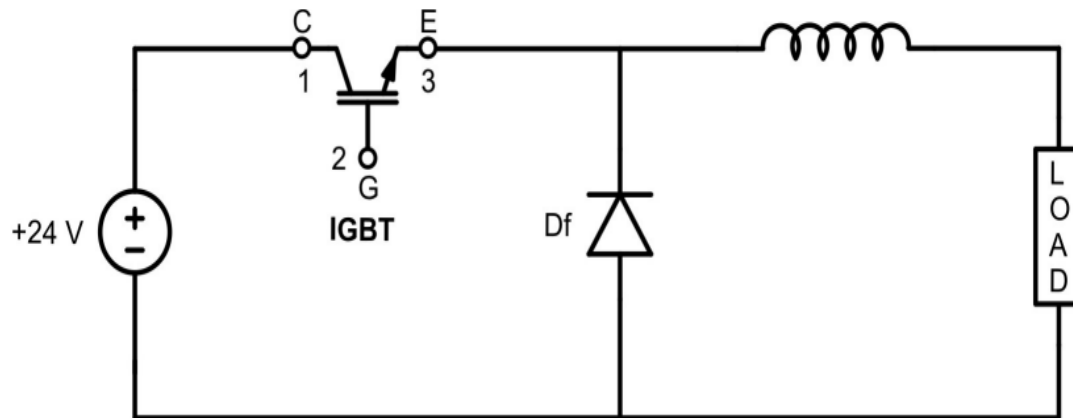

Step Down Chopper

This circuit consists of inductor L , a free-wheeling diode, chopper CH, source and load. Fixed DC input voltage V_s is applied and our aim is to get the variable DC output voltage which is a function of chopper. To get the variable DC voltage, we will switch ON and OFF the chopper CH at some frequency called the chopping frequency.

When CH is switch ON, the source is directly connected to load and hence the output voltage V_o becomes equal to V_s . The time period for which chopper is kept ON is called ON time of chopper and represented by T_{on} . During the ON period of chopper, the current will build in the load exponentially and will reach its maximum value at the end of T_{on} . This simply means that the maximum value of load current I_o will be less than the steady state value. The waveform of load current and time of step-down chopper.

When chopper is switched off, the load is disconnected from the source V_s and hence load voltage V_o will be zero during the entire period for which chopper is Off. The time for which chopper is kept OFF is known as OFF time. As soon as the chopper is switched OFF, the current through the inductor L , output current suddenly drop to zero. Rather, it starts decreasing and hence the polarity of induced emf across the inductor reverse.

This induced emf of inductor makes free-wheeling diode (D) acts as a short during T_{off} . Thus the load current continues to decay through inductor L , free-wheeling diode D and load even through the source V_s is disconnected. The load current reaches its minimum value during OFF time and then chopper is again switched ON.

CIRCUIT DIAGRAM:-

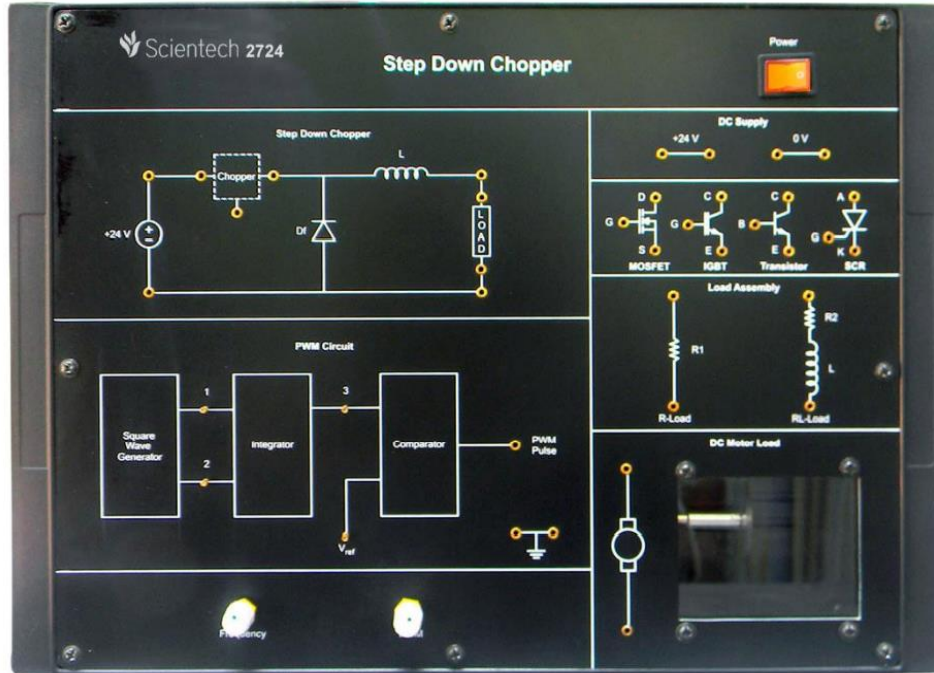

PROCEDURE:-

Make sure that there is no connection on the board initially.

1. Switch on the power supply.
2. Set the frequency of PWM pulse by frequency control potentiometer at 1KHz.
3. Switch off the power supply.
4. Connect the power supply +24V & ground at their indicated positions.
5. Connect the IGBT at chopper section in step down chopper configuration.
6. Connect the PWM pulse from the PWM circuit to the Gate (G) of the IGBT.
7. Connect the Gnd from the PWM circuit to the Emitter (E) of the IGBT.
8. Connect the Motor load at its indicated position.
9. Switch 'On' the power supply.
10. Connect the oscilloscope at the load and vary the PWM control potentiometer & observe the output waveform across the load.
11. Connect the multimeter at the load in DC mode vary the PWM control potentiometer and observe the output voltage across the load.
12. Verify the output DC voltage with the theoretical value.
13. Switch 'Off' the power supply
14. Disconnect all the connections from the board.
15. Set the frequency of PWM pulse by frequency control potentiometer at 500Hz & repeat the experiment.

OBSERVATIONTABLE:-

SI. NO.	Frequency (HZ)	PWM (%)	Measured Output Voltage (v)	Theoretical Output voltage (v)	% error
1					
2					
3					
4					
5					

CALCULATION:-

$$f = 1/T$$

Where f is the chopping frequency (PWM pulse frequency)

T is the time period. $T = T_{on} + T_{off}$

Then The output DC voltage $V_o = V_s \times \frac{T_{on}}{T_{on} + T_{off}}$

$$V_o = V_s \times \frac{T_{on}}{T}$$

$$V_o = V_s \times \alpha$$

Where T_{on} = On time of chopper

T_{off} = Off time of chopper

V_o = Output DC voltage

V_s = Input DC voltage

$$\alpha = \frac{T_{on}}{T} = \text{duty cycle}$$

CONCLUSION:-

By changing the PWM Control Potentiometer from minimum to maximum the output DC voltage across the load changes accordingly with this variation in the DC voltage across the load the speed of motor changes accordingly.

SAFETY & PRECAUTION:-

1. Keep your hand away from main supply.
2. Do not switch on the power supply unless you have checked the circuit connection as per the circuit diagram.

VIVAVOCE QUESTION:-

3. What is chopper.
4. Application of chopper.
5. What is step-down chopper.
6. Define duty cycle.
5. What is the relation between r.m.s value of output with the duty cycler.

Execute Ladder diagrams for different Logical Gates

AIM OF THE EXPERIMENT:- To study of various logic execution in ladder diagram.

EQUIPMENTS:-

1. Computer with SIMATIC software.
2. Siemens S7-1200 PLC
3. LEDs.
4. Switches
5. Connecting wires

THEORY :-

The majority of PLC manufacturers use the ladder logic diagram programming language to program their Programmable Logic controllers (PLCs). Some manufacturers prefer using logic gates circuit or Boolean expression to program their PLCs. Therefore, it is beneficial to know how to convert one type of PLC Programming Language to the other. In this practical, you will learn how to create logic kit circuits from ladder logic diagram and vice-versa. You will review the functions associated with the combinational of logic gates. These gates are the NOT, AND, OR, NAND, NOR, XOR and XNOR gates. You will learn how to create PLC ladder logic diagrams that emulate the function of these Gates.

1. NOT GATE

In electronic, NOT Gate is also called an 'inverter' or 'buffer'.

Working: NOT gate works as inversion. It takes one Input and gives one output. When the input is high then the output is low and vice-versa.

Logic Gate Truth Table for NOT Gate:

Input (A)	Output (Q ₁)
0	1
1	0

NOT Gate in PLC Programming :

In the case of PLC ladder, there will be a push button to provide input. When input (A) is pressed is then the lamp (Q₁) is on. And when input (A) is released then the lamp (Q₁) is off.

Symbolic Representation

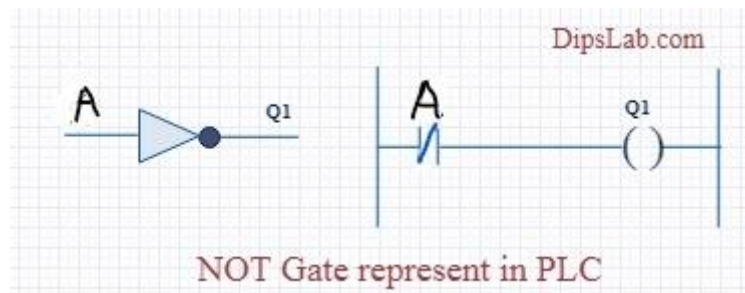

2. AND GATE

Working: In AND Gate, when both inputs 'A' and 'B' are high then the output 'Q₁' will be high. For all other inputs, output 'Q₁' will be low.

Logic Gate truth Table for AND Gate:

Input (A)	Input (B)	Output(Q ₁)
0	0	0
0	1	0
1	0	0
1	1	1

AND Gate in PLC Programming :

Using ladder diagram programming, we are connecting two switches 'A' and 'B' as input and a lamp 'Q₁' as output. In the case of both switches 'A' and 'B' are closed, the lamp 'Q₁' will glow. In another case, if any of the switches ('A' or 'B') are open then lamp 'Q₁' will not glow.

Symbolic Representation as

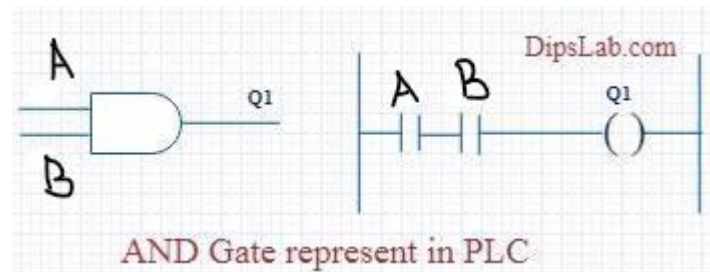

3. OR GATE

Working: If both inputs 'A' and 'B' are low in the OR gate, then the 'Q₁' output will be low. For all other cases, the output 'Q₁' will be high.

Logic Gate Truth table for OR Gate:

Input (A)	Input (B)	Output(Q ₁)
0	0	0
0	1	1
1	0	1
1	1	1

OR Gate in PLC Programming:

In case both or anyone inputs 'A' or 'B' are closed then the lamp 'Q₁' will on.

Symbolic Representation as

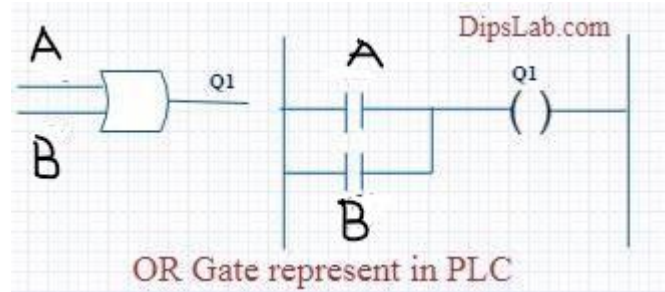

In the above circuit diagram, switch 'A' is pressed then the lamp 'Q₁' will be energized. After releasing switch 'A', the energizing lamp 'Q₁' is providing supplied to switch 'B'. Then switch 'B' will become automatically activated.

4. NAND GATE

NAND Gate is operated as an AND gate and followed by the inverter.

Working: In NAND gate, the output will be low when both input are high. For other cases, the output will be high.

Logic Gate truth Table for NAND Gate:

Input (A)	Input (B)	Output(Q ₁)
0	0	1
0	1	1
1	0	1
1	1	0

NAND Gate in PLC Programming:

If both switches ('A' and 'B') or anyone switch ('A' or 'B') are closed, the lamp will be glow. In the case, both switches are open then the lamp will not be glow.

Symbolic Representation as

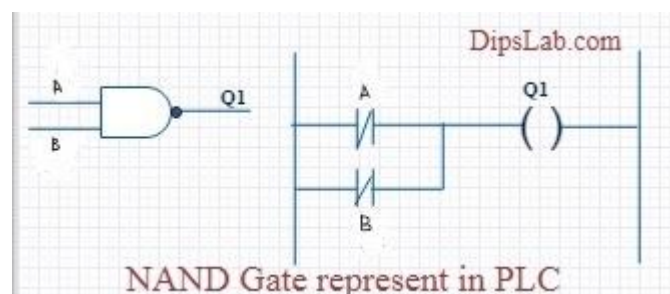

5. NOR GATE

NOR Gate is operated OR gate followed by the NOT Gate.

When both inputs are low then output will be high. Otherwise, the low output will occur if both inputs are high.

Logic Gate truth Table for NOR Gate:

Input (A)	Input (B)	Output(Q ₁)
0	0	1
0	1	0
1	0	0
1	1	0

NOR Gate in PLC Programming:

The lamp 'Q₁' will be activated in both inputs are closed. The lamp 'Q₁' will be deactivated if any one or both inputs are open.

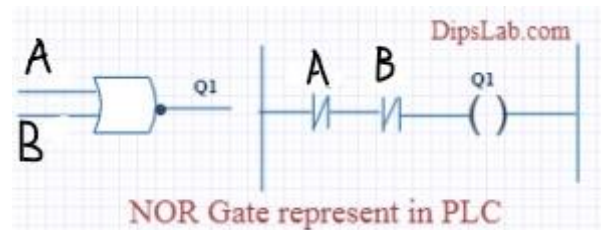

6. X-OR GATE

Working: If both inputs are high or low the output will become low. For any other inputs conditions, the output will be high.

Logic Gate truth Table for X-OR Gate:

Input (A)	Input (B)	Output(Q ₁)
0	0	0
0	1	1
1	0	1
1	1	0

X-OR Gate in PLC Programming:

In the function of XOR Gate, the lamp will be on if one switch is closed and another switch is opened.

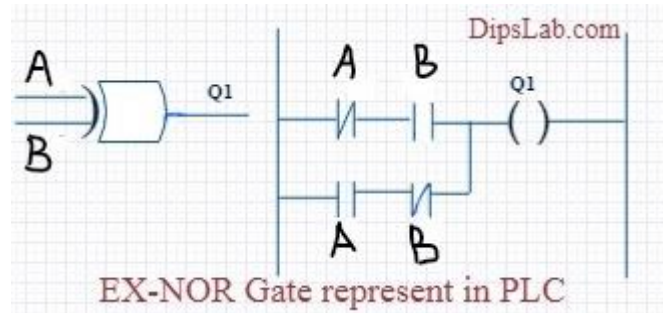

7. X-NOR GATE

Working: when both inputs ('A' and 'B') are high or low the output will be high. If anyone input is high or low then, the output will be become low.

Logic Gate truth Table for X-NOR Gate:

Input (A)	Input (B)	Output(Q ₁)
0	0	1
0	1	0
1	0	0
1	1	1

X-NOR Gate in PLC Programming:

The function of X-NOR Gate, the lamp 'Q₁' will be on if both switches (A and B) are open or closed. The lamp 'Q₁' will not be on if anyone switches (A) is activated and another which (B) is deactivated.

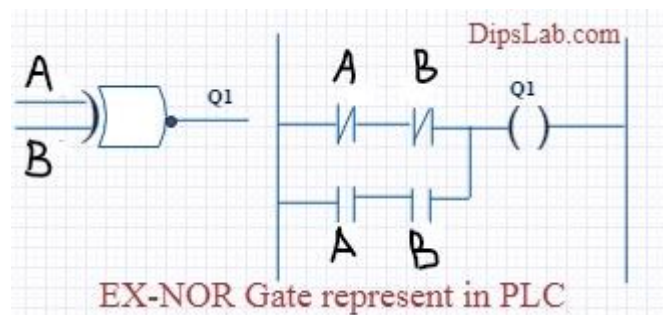

Procedure:-

- Connect to switches to the digital input module.
- Connect the LED to the digital output model.
- Write down the ladder diagram to implement AND- logic functions using SIMATIC Manager software.
- Download the program to the PLC.
- Repeat steps 1 through 4 to implement dish or logic functions.
- Repeat steps 1 through 4 to implement parallel not logic function.

Conclusion:-

This is all about different logic gates using PLC ladder programming. As well as PLC Programming rules and programming instructions are also important for or writing the program.